

Disclaimer

These notes have not been approved by any aviation administration, by any airline nor by the aircraft manufacturer to whom it refers.

At all times use approved company publications and aircraft manufacturer manuals as sole reference for procedures and data ! This info is provided as background information only and may never be used in any way in the operation of any aircraft !

This info may not be current or compatible with your aircraft type, equipment and your company procedures and limitations.

The author/publisher cannot be held responsible for any incorrect information in these notes. **The author/publisher cannot be held responsible for any inconvenience, damage or undesired repercussion on the flight safety, including loss and death,** that results from using information or applying guidelines as described in this publication.



Takeoff Performance

CORRECTIONS

kg

All weights in this chapter are expressed in kg.



To obtain weights in **lbs**, multiply the weight in **kg** by **2.205**

QNH

Correction for QNH must be applied whenever QNH is not equal to 1,013.25 hPa / 29.92 "Hg.



Apply the **QNH Weight increase / penalty** as indicated by the Pressure Correction at the bottom of each WB Table

Eng. A/I

Apply Eng. A/I Correction whenever Eng. A/I is selected ON

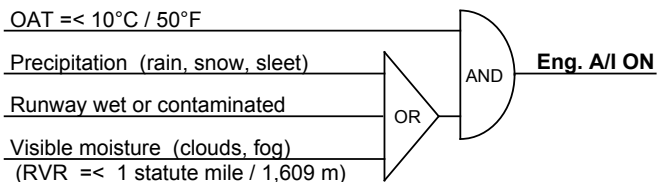

Apply the **Eng. A/I Weight penalty** to the WB Table Weight

	Type	kg
300	20K	-200
	22K	-300
400	22K	-400
	23.5K	-600

	Type	kg
500	18.5K	-300
	20K	-350
NG	 FPPM 1.2.x 1.3.x [Takeoff Field Limit]	

Wet RWY

Apply Wet RWY Correction whenever runway is WET. The runway is considered to be WET when the runway surface is covered with **water with a depth less than or equal to 3 mm / 0.125"** or if there is sufficient moisture on the runway surface to cause it to appear reflective without significant areas of standing water.



- Aborted takeoff calculated with **Antiskid ON**
Antiskid is required for takeoff. If not available → **NOGO**
- Aborted takeoff calculated with max. reverse thrust on remaining engine.
Both Reverses are required for takeoff, unless special tables are available in the WB or takeoff Perf software. You may also apply a simplified conservative method by decreasing the Max. Perf Weight by 1,050 kg and V1 by 2 knots to dispatch with one Reverser INOP.



Apply the **Wet RWY Weight penalty** to the Perf TOW

Type		Perf TOW (1000 kg)							
		36	40	44	48	52	56	60	64
300	20K	0	-300	-800	-1100	-1100	-800	-600	-200
	22K	-200	-500	-800	-1100	-1000	-900	-700	0
400	22K	-500	-800	-1100	-1300	-1300	-1100	-1000	-700
	23.5K	-200	-600	-900	-1100	-1100	-900	-700	-300
500	18.5K	-1000	-800	-800	-900	-1000	-1000	-800	-400
	20K	-500	-700	-700	-800	-900	-800	-800	-500
NG		PI [Slippery runway takeoff - Weight Adjustment - Braking Action Good]							



Apply the following **Wet RWY V1 penalty** to actual TOW V1

Type		Actual TOW (1000 kg)							
		36	40	44	48	52	56	60	64
300	20K	-13	-12	-12	-11	-9	-8	-6	-4
	22K	-14	-14	-13	-12	-10	-9	-7	-6
400	22K	-14	-13	-12	-11	-10	-8	-7	-5
	23.5K	-15	-14	-13	-12	-11	-9	-7	-6
500	18.5K	-12	-11	-10	-10	-9	-7	-5	-4
	20K	-12	-11	-11	-10	-9	-8	-6	-5
NG		PI [Slippery runway takeoff - V1 Adjustment - Braking Action Good]							



After applying V1 penalty, always **check Vmcg**

Type	Highest Vmcg	
300	20K	113
	22K	118
400	22K	119
	23.5K	121

Type	Highest Vmcg	
500	18.5K	107
	20K	111
NG	PI [V1 (mcg)]	



Values in PI [V1 (mcg)] are only valid for full takeoff thrust. This table figures the highest Vmcg for each aircraft type. If V1 drops below, refer to the original table to obtain the exact Vmcg.

BLEED OFF : increase V1(MCG) by 2 kts !
PMC OFF - EEC ALTN : increase V1(MCG) by 3 to 6 kts !

(500) notice difference between V1(MCG) and VR(MCG) !

FULL THRUST METHOD

WEIGHT

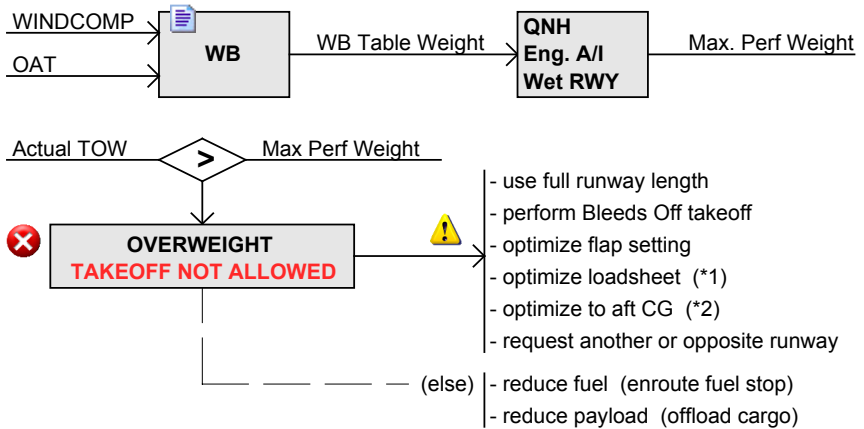

- (*1) JAR 8.1.8.4 [Mass values for passengers and baggage]
Use alternative split mass values for male and female according to your operations.
- (*2) If your laptop perf tool allows for calculation with aft CG, enter the actual MAC as mentioned on the loadsheet. Moving MAC backwards increases the maximum perf takeoff weight up to 800 kg / 1,750 lbs on short field runways.

SPEEDS

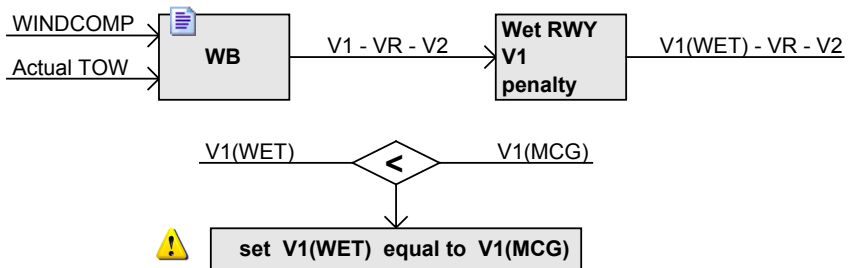

FULL THRUST

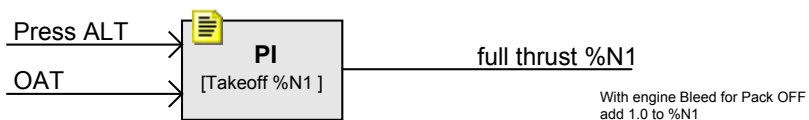

REDUCED THRUST METHOD



Full takeoff thrust may be reduced to a maximum of 25% below the certified rating. However, reduced takeoff thrust is prohibited or not recommended in the following cases :

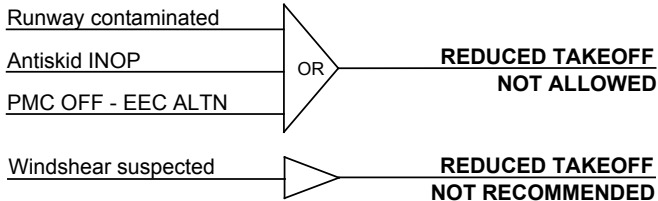

OPS Your company policy may have other constraints and may prohibit reduced thrust perf :

- on short runways or runways in poor condition
- when low visibility procedures are in force
- when wind is exceeding certain crosswind or tailwind values
- when dispatching airplane with the landing gear down
- with one or both reversers INOP or with speed brakes INOP
- with braking action coefficient below 0.40 (GOOD)
- after de-icing
- when using improved climb

ASSUMED TEMP

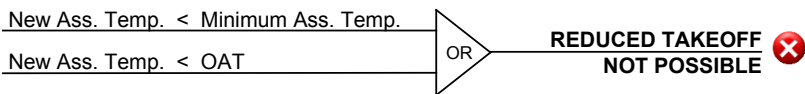
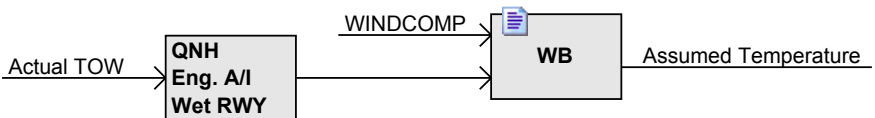

SPEEDS

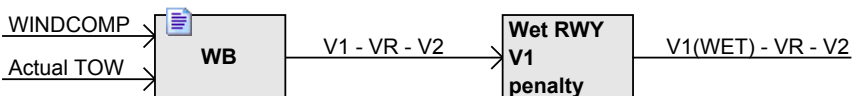

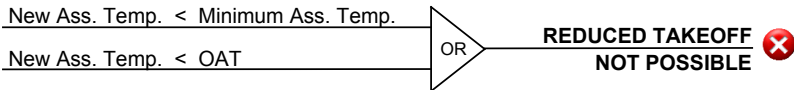
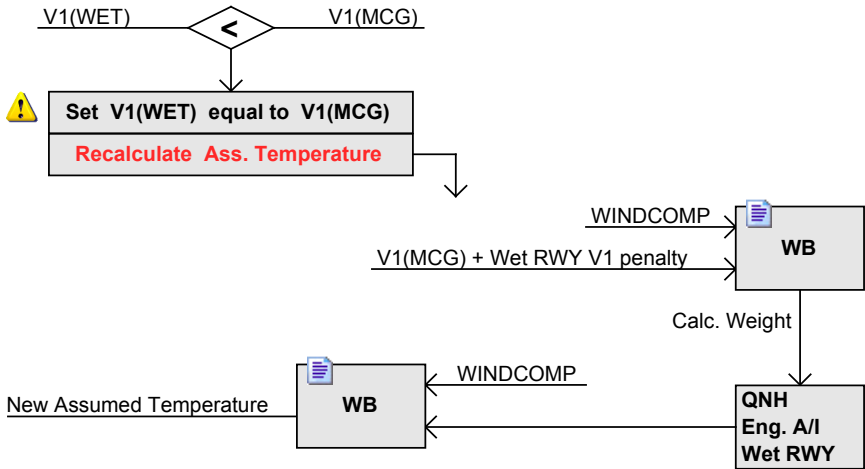

REDUCED THRUST

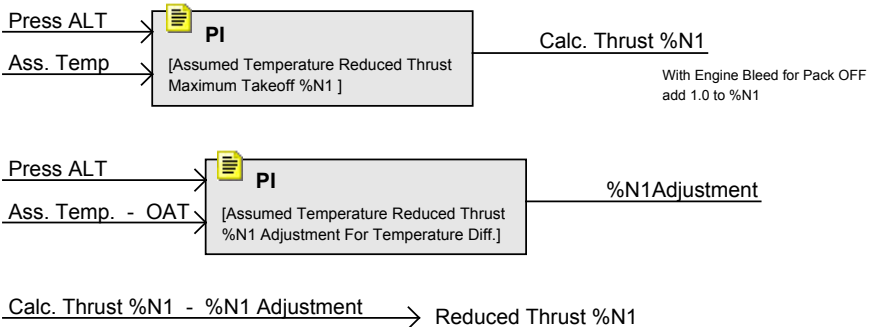

DERATED CLIMB

FCOM 11.30.x [Thrust Management]

If an assumed temperature is inserted in the TAKEOFF REF page, the FMC re-computes CLB-1 and CLB-2 values as required to avoid a climb N1 value higher than the reduced thrust takeoff N1.

CLB-1 is 3% N1 below full rated climb thrust (circa 10% less thrust) and CLB-2 is 6% below full rated climb thrust. (circa 20% less thrust). The derated climb mode gradually increases to full rated climb thrust by 15,000 feet.

Use of derated climb thrust reduces engine maintenance costs, but it increases the total required trip fuel.

CONTAMINATED RUNWAY TAKEOFF



The runway is considered to be contaminated when 25% of its surface area within the required length and width is covered with :

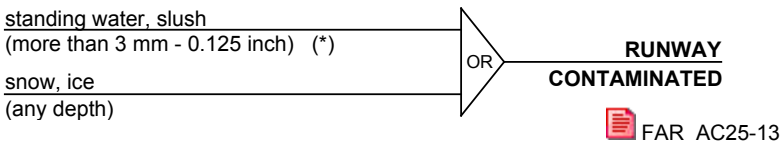
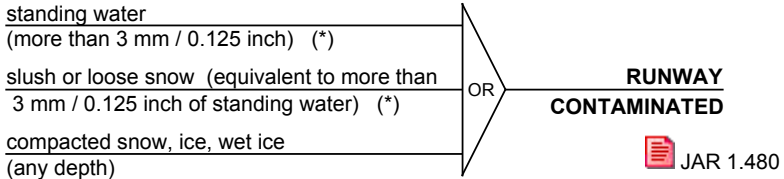

(*) OPS - Your company policy may include 3 mm - 0.125"

TAKEOFF REQUIREMENTS

OPS - Your company policy may have different constraints

Section	Remarks
Takeoff thrust	Reduced takeoff thrust is NOT allowed !
Max. Wind	Reduced crosswind and tailwind limitations according to braking action and/or type of deposit ! Refer to L and OPS.
Brakes	All brakes are required for takeoff. If not available → NOGO
	Antiskid is required for takeoff. If not available → NOGO
	Auto Brake RTO is NOT required and may be INOP.
Reversers	Both reversers are required for takeoff, unless special tables (" Max reverse thrust " and " No reverse thrust ") are available in the WB or Takeoff Perf software.
Fuel	Tankering fuel should be avoided to obtain a lower TOW
De-icing holdover times	Refer to JAR 8.2.4.4 [Holdover times] The start of the holdover time must be referenced from the beginning of the de-icing treatment. The upper holdover time limit value in the table represents light precipitation conditions, while the lower holdover time limit value represents moderate to severe precipitation.

WHICH QRH/FPPM-TABLE TO USE



PI 10.x



FPPM 1.2.x - 1.3.x

Class	Type of deposit
HARD	compacted snow, ice, wet ice
FLUID	standing water, slush, wet snow dry loose snow

- Table **[Slippery Runway Takeoff]**

Use this table for takeoff on **HARD class** contaminated runways. As the aircraft is rolling on top of the contamination, depth of deposit is no factor. There is no drag penalty during acceleration. However stopping distance in case of aborted takeoff is increased due to reduced tire friction when braking.

Braking Action	POOR					P / M					MEDIUM					M / G					GOOD				
	91					92					93					94					95				
Coefficient μ x 100	0	10	20	25	26	27	28	29	30	31	32	33	34	35	36	37	38	39	40	50	100				



Takeoff is NOT allowed with braking action POOR



OPS Your company policy may also prohibit takeoff when braking action is reported P/M (Poor to Medium) and/or takeoff on ice.

- Table **[Slush/Standing Water Takeoff]**

Use this table for takeoff on **FLUID class** contaminated runways. Acceleration (increased drag and aquaplane) and also deceleration performance (reduced friction coefficient) are both affected as the aircraft is rolling through the deposit. This explains the larger weight penalty for takeoff on contaminated runways with standing water or slush compared to slippery runways.

One and the same table is used for both slush and standing water, assuming that the performance penalty is equal for both kinds of deposit. If your weight book or takeoff perf software does not accept dry loose snow inputs, you can use the following table for conversion. Ratios vary between airlines and go from 1/4 till 1/8. This table uses the most restrictive ratio 1/4 :

Class	Type of contamination	Conversion table (ratio 1/4)				
FLUID	standing water, slush, wet snow	> 3 mm > 0.125"	6 mm 0.250"	13 mm 0.500"	> 13 mm > 0.500"	
	dry loose snow	> 12 mm > 0.500"	24 mm 1.000"	52 mm 2.000"		> 102 mm > 4.000"

(e.g. 24 mm of dry loose snow equals 6 mm of wet snow)



FCTM 3.x [Adverse Runway Conditions] **To avoid damage to the airplane, takeoff is not recommended on runways with contamination within the red shaded area !** For airports at or above 8,000 feet, this recommendation goes also for the green shaded areas.

FULL THRUST

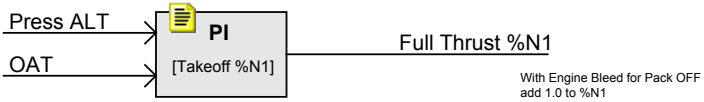

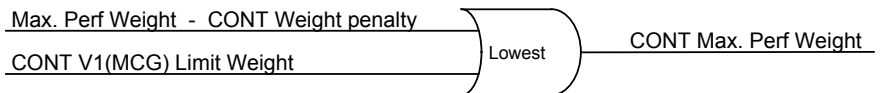
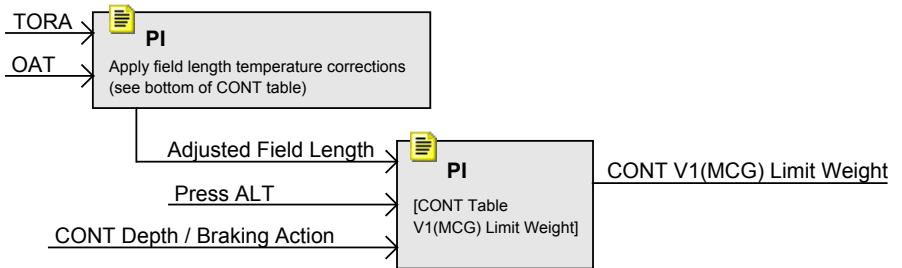
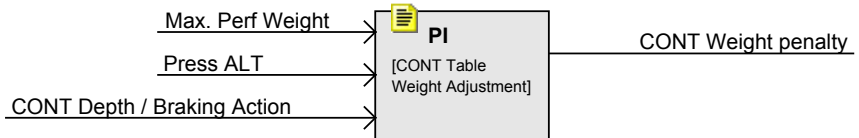
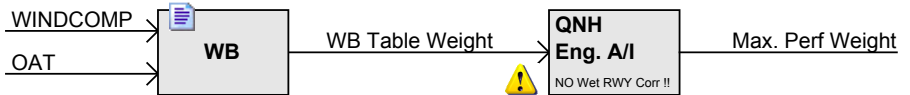

WEIGHT



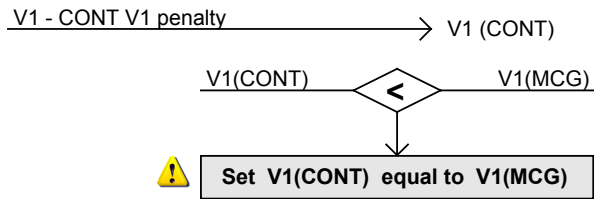
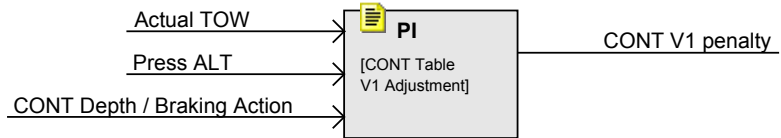
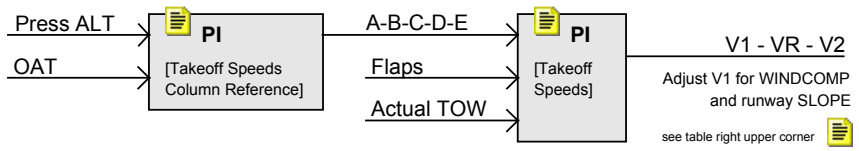

SPEEDS





DISPATCH WITH PMC OFF - EEC ALTN

Refer to (CL)  MEL 73-07 [Power Management Control Systems (PMC)]
 (NG)  MEL 73-11 [Electronic Engine Control (EEC)]

- Select **both** PMC to OFF / EEC to ALTN. The PMC/EEC control switches are located on the aft OVHD panel or (as installed) in the E&E compartment.
- Use **full takeoff thrust** :
 - (CL) accomplish  SP 7.x [PMC OFF Takeoff and Climb]
 - do not derate engine thrust, except for (700) under specified conditions
 - do not use the assumed temperature method reduced takeoff thrust
- Do not use FMS calculated takeoff **V-speeds**.
- Except for thrust level 26K and above, the FMS takeoff **N1** values are valid.
- Unless not in line with your airline  OPS, the **Autothrottle may be used ON** for takeoff, except for thrust levels 26K and above.
 During takeoff run, with manual thrust setting or with the autothrottle in [THR HLD] N1 indications may increase up to 7% due to windmilling : **DO NOT ADJUST !**

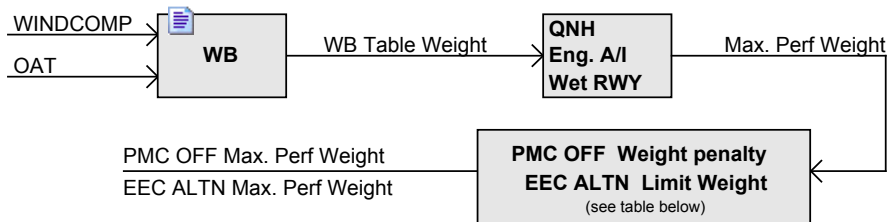
WEIGHT



=		=				<i>Based on the lowest values from</i>  FPPM 1.2.x 1.3.x [Takeoff Field Limit] [Takeoff Climb Limit] [Obstacle Limit]
300	20K	0				
	22K					
OAT		≤ 21°C	> 21°C			
400	22K	-4970				
	23.5K	-4420				
Actual TOW 1000kg		30	40	50	60	
500	18.5K	-3700	-2600	-1500	-400	
	20K					
=		=				
NG		Enter  FPPM 4.4.x [Alternate Mode EEC Limit Weight] with the Max. Perf Weight and read the EEC ALTN Max. Perf Weight (= the lowest of the 3 values Field-Climb-Obstacle)				

SPEEDS

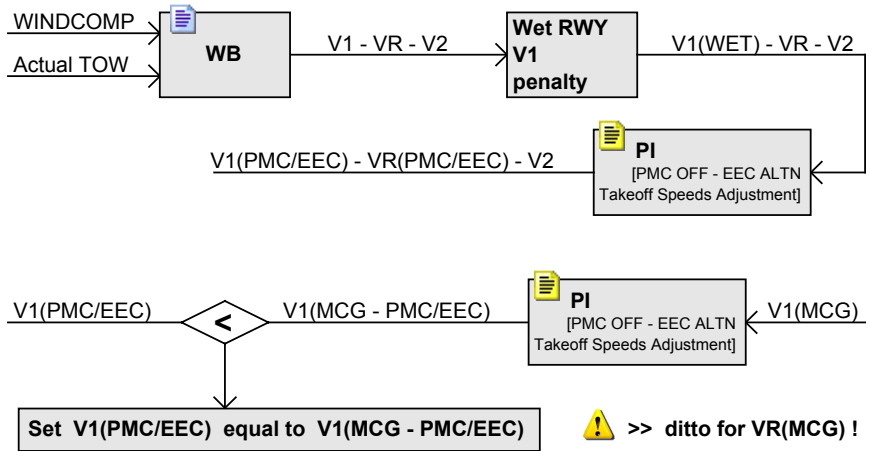

FULL THRUST

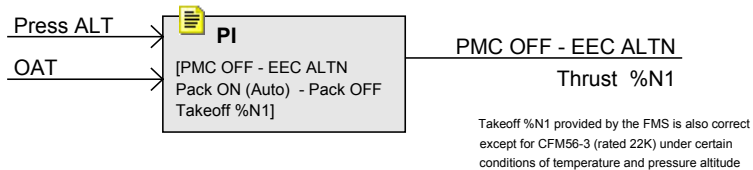

DISPATCH WITH ANTISKID INOP

Takeoff :

- runway may not be **wet** or **contaminated**
- **Reduced** takeoff thrust **not allowed**

 OPS Your company policy may impose more constraints, such as no tailwind, no tankering fuel, both reversers available, no improved climb.

Landing :

 OPS Landing minimums CAT I - Verify Lower Landing Minimum Requirements Table

Verify **landing distance** at destination and at takeoff alternate

 PI [Adv. Info - Non-Normal Config. Landing Distance]

WEIGHT

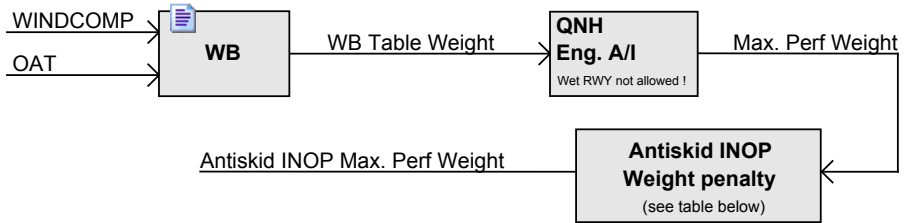

	Type	kg
300	20K	-7000
	22K	-7800
400	22K	-7700
	23.5K	-7500
500	18.5K	-7100
	20K	-7500

	Type	kg
600	22K	-7050
	700	24K
800	26K	-8500
	900	26K
BBJ	27K	-8250
	BB2	

Based on  PI -  FPPM Introduction Text

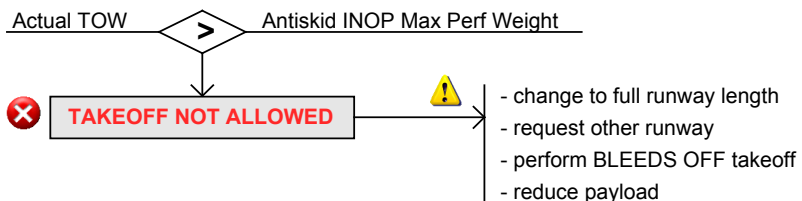

SPEEDS

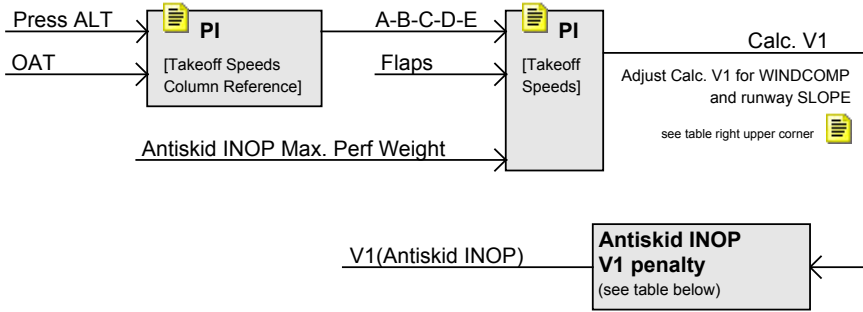

Type		TORA (feet)				
		6000	8000	10000	12000	14000
300	20K	-27	-22	-17	-14	-11
	22K	-27	-22	-18	-15	-12
400	22K	-28	-21	-17	-14	-11
	23.5K	-28	-22	-18	-14	-13
500	18.5K	-30	-23	-18	-14	-11
	20K	-31	-24	-19	-15	-12
600	22K	-18	-14	-12	-11	-9
700	24K	-18	-14	-12	-10	-9
800	26K	-20	-16	-14	-12	-11
900	26K	-22	-18	-15	-13	-11
BBJ	27K	-19	-15	-13	-11	-10
BB2						

Based on PI - FPPM introduction text

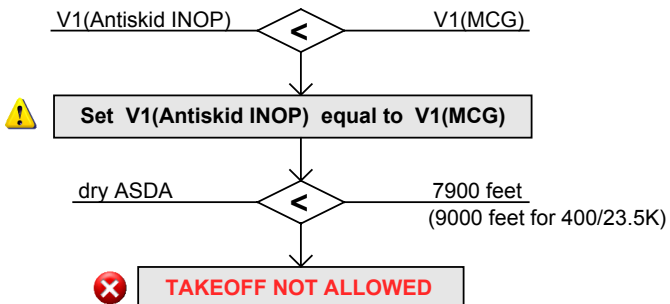

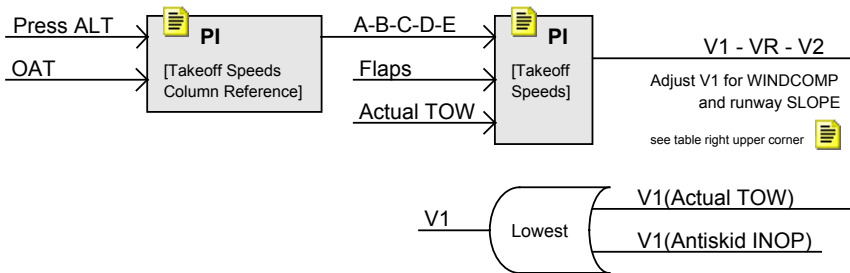

FULL THRUST

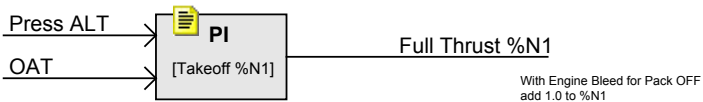

NON-AVAILABILITY OF "BLEEDS OFF" WB TABLE



Apply this procedure after decision to takeoff with BLEEDS OFF when there is no WB table is available.



- Refer to full thrust method for computation of Max. Perf Weight, Speeds and Thrust N1
- Increase Max. Perf Weight by the lowest value mentioned below the following tables :
 - FPPM 1.2.x - 1.3.x [Takeoff Field Limit]
 - [Takeoff Climb Limit]
 - [Obstacle Limit]
- Increase Takeoff N1 by 1.0
- Verify V(MBE) using FPPM 1.2.x - 1.3.x [Brake Energy Limits (VMBE)]
- Verify V(TIRE) using FPPM 1.2.x - 1.3.x [Tire Speed Limit]